

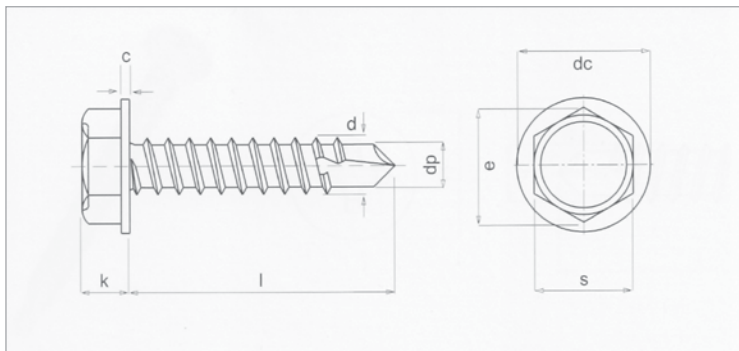

## VITI AUTOPERFORANTI



## VITI AUTOPERFORANTI A TESTA ESAGONALE FINTA RONDELLA



## MATERIALI DISPONIBILI

ACCIAIO CEMENTATO HV 560  
ZINCATO  
ACCIAIO INOX A2

d	3,5	3,9	4,2	4,8	5,5	6,3
dc max	8,30	8,30	8,80	10,50	11	13,50
dp	2,80	3,10	3,60	4,10	4,80	5,80
s	5,50	5,50	7,00	8,00	8,00	10,00
e min	9,96	9,96	7,59	8,71	8,71	10,95
k max	3,40	3,40	4,10	4,30	5,40	5,90
c min	0,60	0,60	0,80	0,90	1,00	1,00

## VITI AUTOPERFORANTE A TESTA CILINDRICA CROCE

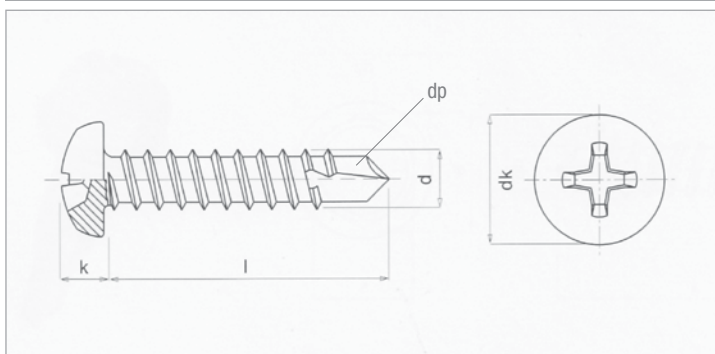

## MATERIALI DISPONIBILI

ACCIAIO CEMENTATO HV 560  
ZINCATO  
ACCIAIO INOX A2

d	2,9	3,5	3,9	4,2	4,8	5,5	6,3
dk max	5,60	6,90	7,50	8,20	9,50	10,80	12,5
k max	2,20	2,60	2,80	3,05	3,55	3,95	4,55
dp	2,30	2,80	3,10	3,60	4,10	4,80	5,80
bit	ph1	ph1	ph2	ph2	ph2	ph3	ph3

## VITI AUTOPERFORANTI SVASATE A CROCE

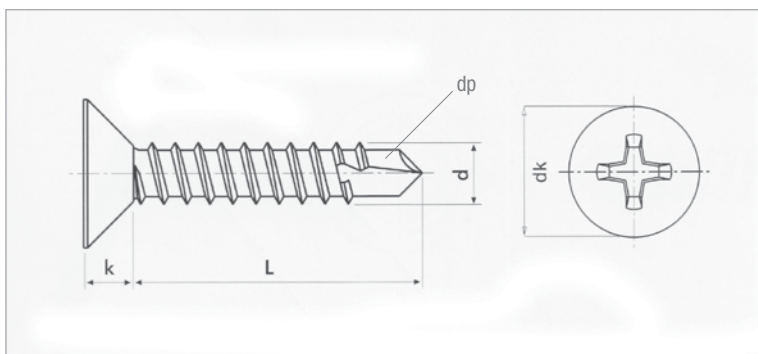

## MATERIALI DISPONIBILI

ACCIAIO CEMENTATO  
 HV 560 ZINCATO  
 ACCIAIO INOX A2

d	2,9	3,5	3,9	4,2	4,8	5,5	6,3
dk	5,50	6,80	7,30	8,10	9,50	10,80	11,40
k	1,70	2,10	2,30	2,50	2,80	3,40	3,80
dp	2,30	2,80	3,10	3,60	4,10	4,80	5,80
bit	ph1	ph1	ph2	ph2	ph2	ph3	ph3