

Conical spring washers
for screw and washer assemblies

DIN
6908

ICS 21.060.30

Supersedes December 1990 edition.

Descriptors: Conical spring washers, screws, fasteners, washers.

Spannscheiben für Kombi-Schrauben

In keeping with current practice in standards published by the International Organization for Standardization (ISO), a comma has been used throughout as the decimal marker.

Foreword

This standard has been prepared by the *Normenausschuss Mechanische Verbindungselemente* (Fasteners Standards Committee).

A revision of the December 1990 edition was necessary to account for problems which have arisen when screw and washer assemblies include conical spring washers of nominal sizes 5,5 to 11, with low values for h . Therefore, these values have been significantly increased, the minimum values after testing for permanent set remaining nevertheless unchanged.

As these altered specifications do not conflict with the requirements specified in DIN 267-26, the interchangeability of products has not been affected.

Amendments

The following amendments have been made to the December 1990 edition.

- a) For sizes from 5,5 to 11, the minimum and maximum values of h , h_{min} and h_{max} , have been amended.
- b) The standard has been editorially revised.

Previous editions

DIN 6908: 1972-12, 1990-12.

Dimensions in mm

1 Scope and field of application

This standard specifies dimensions and technical delivery conditions for conical spring washers which are intended for use with screw and washer assemblies as specified in DIN 6900-5. They are designed for use with bolted connections with bolts of property classes 8.8 to 10.9 (as specified in DIN EN 20 898-1). Conical spring washers are intended to counteract loosening of such connections (e.g. as a result of setting) (cf. DIN 267-26). They do not effectively prevent loosening of the connection under varying radial loads and are thus designed for use with short screws predominantly subject to thrust.

2 Normative references

This standard incorporates, by dated or undated reference, provisions from other publications. These normative references are cited at the appropriate places in the text, and

the publications are listed hereafter. For dated references, subsequent amendments to or revisions of any of these publications apply to this standard only when incorporated in it by amendment or revision. For undated references, the latest edition of the publication referred to applies.

DIN 267-26

Fasteners; technical delivery conditions; steel spring washers for bolt/nut assemblies

DIN 1544

Steel flat products; cold rolled steel strip; dimensions, limit deviations and form tolerances

DIN 4000-3

Tabular layouts of article characteristics for washers

DIN 6900-5

Screw and washer assemblies; coarse threaded screws with captive conical spring washer

DIN EN 20 898-1

Mechanical properties of fasteners; bolts, screws and studs (ISO 898-1: 1988)

Continued on pages 2 and 3.

3 Dimensions

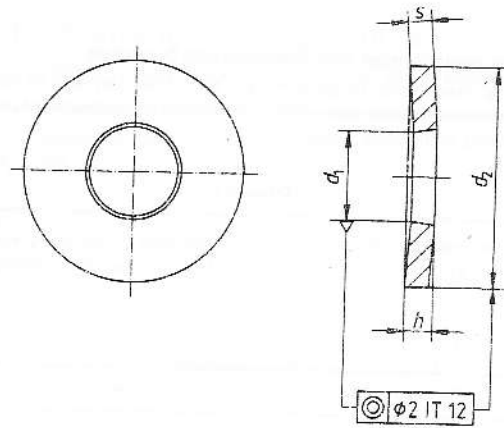

Figure 1

Table 1

Dimensions in mm

Nominal size	d_1		d_2		$s^2)$	As delivered condition		h	Mass (7,85 kg/dm ³) per 1 000 units, in kg	For thread size
	min. = nominal size	max.	max. = nominal size	min.		max.	min.			
2,25 ³⁾	2,25	2,35	6	5,70	0,5	0,72	0,61	0,61	0,10	M2,5
2,75 ³⁾	2,75	2,85	7	6,64	0,6	0,85	0,72	0,72	0,15	M3
3,2 ³⁾	3,20	3,32	8	7,64	0,8	1,06	0,92	0,92	0,27	M3,5
3,6	3,60	3,72	9	8,64	1,0	1,30	1,12	1,12	0,42	M4
4,55	4,55	4,67	11	10,57	1,2	1,55	1,35	1,35	0,74	M5
5,5	5,50	5,62	14	13,57	1,5	2,60	2,30	1,70	1,53	M6
7,4	7,40	7,55	18	17,57	2,0	3,10	2,80	2,24	3,32	M8
9,3	9,30	9,45	23	22,48	2,5	3,60	3,30	2,80	6,82	M10
11	11,0	11,18	29	28,48	3,0	4,10	3,80	3,43	13,3	M12

1) The specifications for the minimum free height of washers in table 5 of DIN 267-26, October 1987 edition, do not apply here.
 2) The limit deviations for s shall be as specified in DIN 1544.
 3) No spring force test values have as yet been specified for these nominal sizes.

4 Technical delivery conditions

Conical spring washers shall be made of FSt steel as specified in DIN 267-26 and comply with the technical delivery conditions specified there.

5 Designation

Designation of a size 9,3 conical spring washer made of spring steel (FSt)¹⁾:

Conical spring washer DIN 6908 – 9,3 – FSt

The DIN 4000 – 3 – 3 tabular layout of article characteristics shall apply to conical spring washers as specified in this standard.

¹⁾ Grade FSt steel shall also be used where no material is specified in existing documentation.